

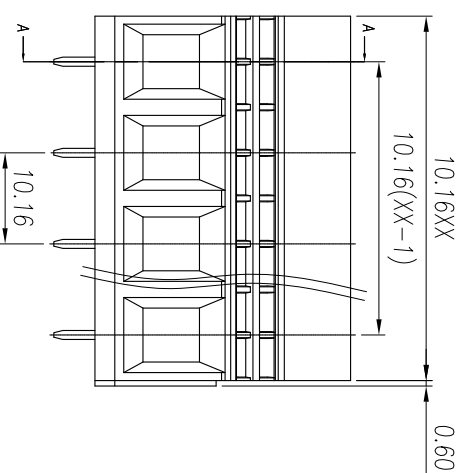

# 慈溪市万捷电子有限公司 CIXI WANJIE ELECTRONIC CO., LTD

产品规格书  
THE SPEC SHEET

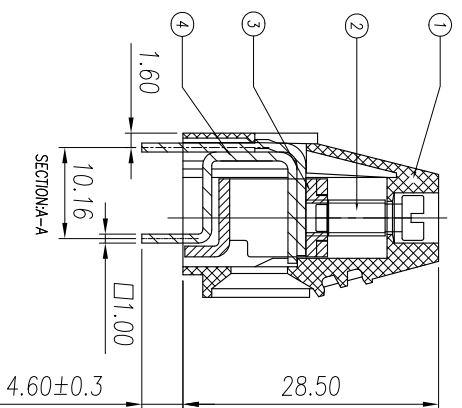
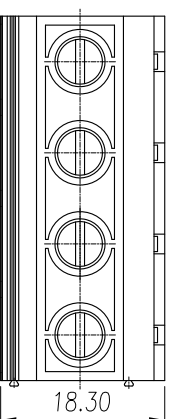
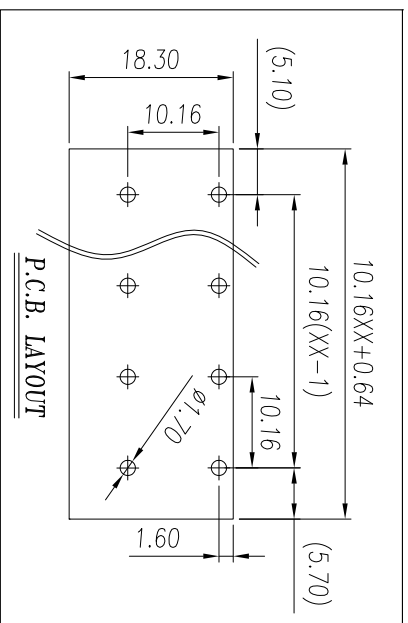

### 电气性能/Electrical

参考标准/Standard	UL	IEC
额定电压/Rated voltage	600V	650V
额定电流/Rated current	65A	57A
接触电阻/Contact resistance	20mΩ	
绝缘电阻/Insulation resistance	500MΩ/DC500V	
使用线径/Wire range	20-6AWG	16mm <sup>2</sup>
耐电压/With standing voltage	AC 2500V/1 Min	

### 机械性能/Mechanical

扭矩/Torque	1.8Nm(15.6Lb.in)
剥线长度/Strip length:	10-11mm
温度范围/Temp. Range	-40°C~+105°C
瞬时温度/MAX Soldering	+250°C, for 5 Sec

### 尺寸/Dimensions

间距/Pitch	10.16mm
极数/Poles	2-18P

### 材料及电镀/Material

塑件/Housing	PA66, UL94V-0
螺丝/Screws	M4.0 Steel Zn plated
焊脚/Pin header	Copper alloy Tin plated
方块/Cage	Steel Zn plated

linear dimension(Tolerances Standard GB/T 14486-2008)

tolerance	±0.1	±0.14	±0.19	±0.25	±0.32	±0.43	±0.57	±0.72	±0.88	±1.05	±1.25	0.5	0.025	0.06	0.12	0.4
variable range	to 6	over 6 to 10	over 10 to 18	over 18 to 30	over 30 to 50	over 50 to 80	over 80 to 120	over 120 to 160	over 160 to 200	over 200 to 250	over 250 to 300	all	to 5	over 5 to 30	over 30 to 120	over 120 to 150

单位/UNITS	mm
尺寸/SIZE	A4
比例/SCALE	1:2.1

慈溪市万捷电子有限公司  
CIXI WANJIE ELECTRONIC CO., LTD

第三视角/THIRD ANGLE PROJECTION



名称/TITLE  
WJ16W-10.16-XXP-YY-00A