

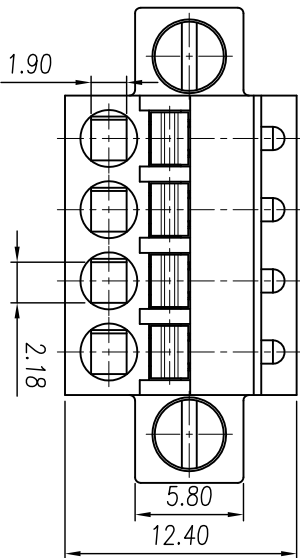

慈溪市万捷电子有限公司 CIXI WANJIE ELECTRONIC CO., LTD

产品规格书
THE SPEC SHEET

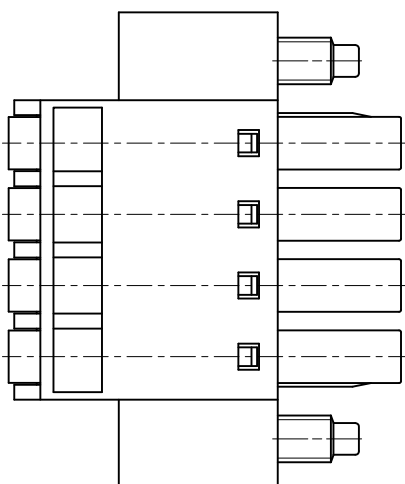
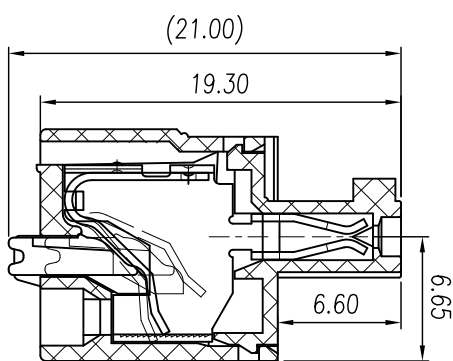
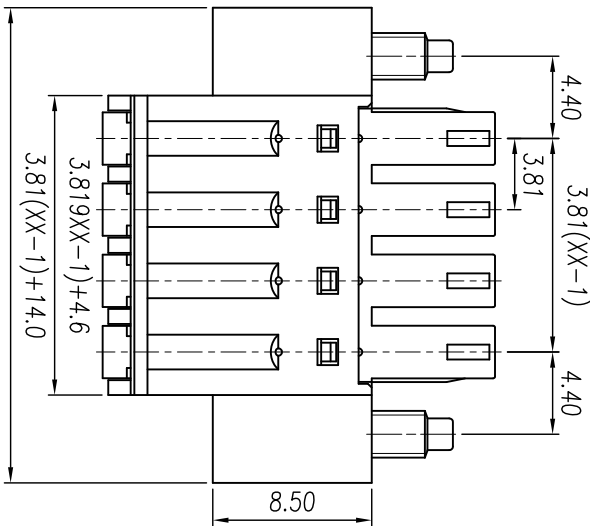

参考标准/Standard
 额定电压/Rated voltage
 额定电流/Rated current
 接触电阻/Contact resistance
 绝缘电阻/Insulation resistance
 使用线径/Wire range
 耐电压/Wvth standing voltage

机械性能/Mechanical
 剥线长度/Strip Length
 温度范围/Temp. Range
 扭矩/Torque
 尺寸/Dimensions
 间距/Pitch
 极数/Poles
 材料及电镀/Material

塑料/Housing
 螺丝/Screws
 夹子/Clamp
 弹片/Wire guard

| | | | | | | | | | | | | | | | | |
|----------------|-----------|------------|------------|------------|------------|------------|-------------|-------------|-------------|-------------|-------|-----------|------------|-------------|------|-----|
| variable range | over 6 to | over 10 to | over 18 to | over 30 to | over 50 to | over 80 to | over 120 to | over 160 to | over 200 to | over 250 to | all | over 5 to | over 30 to | over 120 to | | |
| | 6 | 10 | 18 | 30 | 50 | 80 | 120 | 160 | 200 | 250 | | 5 | 30 | 120 | | |
| tolerance | ±0.1 | ±0.14 | ±0.19 | ±0.25 | ±0.32 | ±0.43 | ±0.57 | ±0.72 | ±0.88 | ±1.05 | ±1.25 | 0.5 | 0.025 | 0.06 | 0.12 | 0.4 |

linear dimension(Tolerances Standard GB/T 14486-2008)

单位/UNITS mm 尺寸/SIZE A4 比例/SCALE 3:1



慈溪市万捷电子有限公司
CIXI WANJIE ELECTRONIC CO., LTD

第三视图/THIRD ANGLE PROJECTION



名称/TITLE
WJ5ED30M-3.81-XXP-1YY-00A