

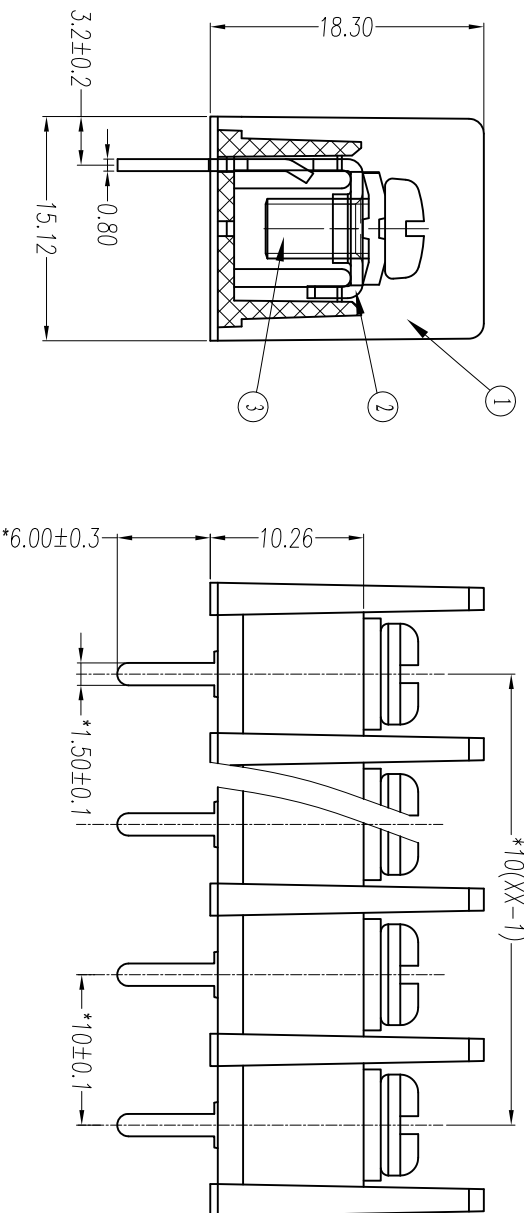

慈溪市万捷电子有限公司 CIXI WANJIE ELECTRONIC CO., LTD

产品规格书
THE SPEC SHEET

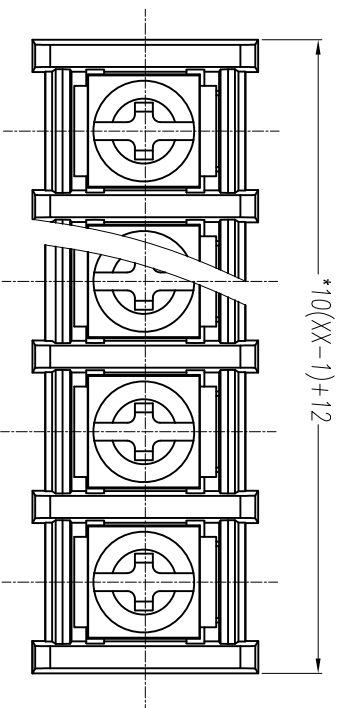
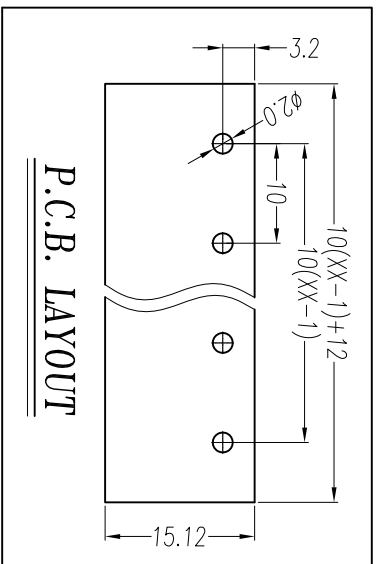

电气性能/Electrical

参考标准/Standard	UL	IEC
额定电压/Rated Voltage	300V	750V
额定电流/Rated current	20A	24A
接触电阻/Contact resistance	20mΩ	
绝缘电阻/Insulation resistance	500MΩ/DC500V	
使用线径/Wire range	22~12AWG	2.5mm ²
耐电压/With standing voltage	AC 2000V/1 Min	

机械性能/Mechanical

扭矩/Torque	1.2Nm(10.6lb.in)
温度范围/Temp.Range	-40°C~+105°C
瞬时温度/MAX Soldering	+250°C, for 5 Sec

尺寸/Dimensions

间距/Pitch	10mm
极数/Poles	2~24p
材料及电镀/Material	PA66, UL94V-0
塑件/Housing	M4.0 Steel Ni plated
螺丝/Screws	Brass 0.8t Tin plated
焊脚/Pin header	

variable range	over 6 to 10	over 10 to 18	over 18 to 30	over 30 to 50	over 50 to 80	over 80 to 120	over 120 to 160	over 160 to 200	over 200 to 250	over 250 to 500	over 500 to 1000	over 1000 to 2000	over 2000 to 5000	over 5000 to 10000	over 10000 to 20000	over 20000 to 50000	over 50000 to 100000	over 100000 to 200000	over 200000 to 500000	over 500000 to 1000000
	tolerance	±0.1	±0.14	±0.19	±0.25	±0.32	±0.43	±0.57	±0.72	±0.88	±1.05	±1.25	0.5	0.025	0.06	0.12	0.4			

单位/UNITS mm 尺寸/SIZE A4 比例/SCALE 2:1



慈溪市万捷电子有限公司
CIXI WANJIE ELECTRONIC CO., LTD

第三视图/THIRD ANGLE PROJECTION



名称/TITLE
WJ55S-XXP-1YY-00A